

Isolation and Characterization of Extracellular Biofloculants Produced by Bacteria Isolated from Qatari Ecosystems

DESOUKY A.M. ABD-EL-HALEEM^{1,2*}, RODA F. AL-THANI¹, THOURYA AL-MOKEMY¹,
SIDRA AL-MARII¹ and FATIMA HASSAN¹

¹ Biological and Environmental Sciences Department, College of Arts and Sciences,
Qatar University, 2713 Doha, Qatar

² Environmental Biotechnology Research Department, Genetic Engineering
and Biotechnology Research Institute Mubarak City for Scientific Research and Technology Applications,
New Burg Elarab City, Alexandria, Egypt

Received 8 May 2008, revised 28 July 2008, accepted 31 July 2008

Abstract

Compared with conventional synthetic flocculants, biofloculants has special advantages such as safety, strong effect, biodegradable and harmlessness to humans and the environment, so they may potentially be applied in drinking and wastewater treatment, downstream processing, and fermentation processes. To utilize biofloculants widely in industrial fields, it is desirable to find various microorganisms with high biofloculant-producing ability and improve the flocculating efficiency of the biofloculant. In the present study, screening of new flocculant-producing microorganisms was carried out using samples collected from different Qatari ecosystems. The flocculating activity of the novel biofloculants produced by isolated microorganisms was investigated. A total of 5 g/l Kaolin suspension was used to measure the flocculating activity. Isolated biofloculant-producing bacteria were identified by 16S rDNA analysis, using PCR with universal primers. Comparative analysis of the 16S rDNA sequence (~550 bp) in the GenBank database revealed that these bacteria are related to the genus *Bacillus*. FT-IR spectrometry analysis of the extracted biofloculants indicated the presence of carboxyl, hydroxyl and amino groups preferred for the flocculation process. Influences of pH and biofloculant dosage on the flocculation were also examined. The maximum flocculating rates were observed at pH 7, 7 and 3 of the biofloculants derived from strains QUST2, QUST6 and QUST9, respectively. However, 20.0 mg/l was the dose that gave the highest flocculating rate with all examined biofloculants. The elemental analysis of examined biofloculants revealed the mass proportion of C, H, N and S. Carbon and nitrogen contents of examined biofloculants were in the range of 42–48% and 11–12%, respectively.

Key words: biofloculants, FT-IR, Qatari ecosystems, screening for *Bacillus*

Introduction

Biofloculant is a type of flocculant that is produced by microorganisms but is readily degradable. Its degradation intermediates are harmless to humans and the environment. In recent years, several kinds of microorganisms, which secreted flocculating biopolymer, have been screened and isolated from activated sludge, soil, and wastewater. The species include bacteria, fungi, actinomyces and algae. Generally, soil and activated sludge samples are the best sources for isolating biofloculant-producing microorganisms.

Previously, *Phormidium* J-1, a benthic filamentous cyanobacterium, isolated from a drainage channel,

was found to produce a high molecular weight (MW) polymer which can flocculate bentonite particles from suspensions. *Rhodococcus erythropolis* produced a biofloculant named NOC-1 with an efficient activity in causing flocculation of a wide range of suspended solids (Kwon *et al.*, 1996). The biofloculant purified from the culture broth of *Archuadendron* sp. TS-49 could efficiently flocculate various microorganisms and organic/inorganic materials (Li *et al.*, 2003).

Enterobacter cloacae WD7 was also reported to generate a viscous culture broth exhibiting flocculating activity. Significantly, many reported microorganisms which could secrete biopolymer flocculant belong to *Bacillus* sp. (Salehizadeh and Shojaosadati, 2001;

* Corresponding author: D. Abd-El-Haleem, Environmental Biotechnology Research Department, Genetic Engineering and Biotechnology Research Institute, Mubarak City for Scientific Research and Technology Applications, New Burg Elarab City, Alexandria, Egypt, phone: (2) 034593420; e-mails: desouky.a@qu.edu.qa, abdelhaleemm@yahoo.de

Deng *et al.*, 2003; Kwon *et al.*, 1996; Suh *et al.*, 1997). He *et al.* (2004) investigated the production of a polygalacturonic acid bioflocculant REA-11 from a newly isolated strain, *Corynebacterium glutamicum* CCTCC M201005. Kurane *et al.* (1986) reported that *Nocardia restricta*, *Nocardia calcarea* and *Nocardia rhodnii* could produce biopolymer flocculants. A strain *Saccharomycete* STSM-1 with flocculating activity was isolated from activated sludge (Chen *et al.*, 2003). Deng *et al.*, found that *Aspergillus parasiticus* could produce a bioflocculant with a flocculating activity for Kaolin suspension and water-soluble dyes (Deng *et al.*, 2005). Although many studies on the bioflocculants have been done, flocculating activity and culture cost of bioflocculants are still the major limiting factors with regard to their application (Li *et al.*, 2003).

Generally, screening for bioflocculant-producing microorganisms is based on the colony morphology (mucoid and ropy) and capsule production. The flocculating efficiency of the bioflocculant is evaluated by the ability to remove suspended solids, pigments or chemical oxygen demand (COD). The bioflocculants from microorganisms are also purified and identified. It was reported that most of them were functional proteins (Takagi and Kadowaki, 1985; Zhang *et al.*, 1999) or functional polysaccharides (Huang *et al.*, 2005; He *et al.*, 2004). In this article, screening and isolation of novel bioflocculant-producing bacteria from various Qatari ecosystems were done. The characteristics and flocculation properties of the secreted bioflocculants were subjected for further analysis.

Experimental

Materials and Methods

Sampling. Samples were collected from different Qatari ecosystems. Three soil samples were collected from the upper 30 cm of Dafna, Smasmah (SABAKHAT, north of Doha, Qatar) and the green area at college of Arts and Sciences (CAS), Qatar University, Qatar. A sewage wastewater sample was also collected at the same time from the constructed wetland wastewater treatment plant at south of Doha, Qatar.

Preparation of samples. A total of 10 grams soil or 100 ml wastewater were transferred to 500 ml beaker and diluted by the addition of 400 ml distilled water. Then the diluted samples were stirred for 30 min at 225 rpm and precipitated for 30 min. The 5 ml supernatant obtained from the beaker, was cultured in YPG medium with composition of peptone 20.0 g, yeast extract 10.0 g and glucose 20.0 g per liter of deionized water at pH 6.5 (Chen and Zhao, 2003). The growth experiments were performed in 250 ml flask on a conical orbital shaker (150 rpm) at

30°C for 2 days in YPG medium. The culture broth was then used for the isolation of bioflocculant-producing microorganisms.

Screening and isolation. The composition of the isolation medium was as follows: 20 g/l soluble starch, 1 g/l KNO_3 , 0.5 g/l $\text{MgSO}_4 \times 7\text{H}_2\text{O}$, 0.5 g/l NaCl, 0.5 g/l $\text{K}_2\text{HPO}_4 \times 3\text{H}_2\text{O}$, 0.01 g/l $\text{FeSO}_4 \times 7\text{H}_2\text{O}$, and 15–20 g/l agar powder (Zheng *et al.*, 2008). Serial concentrations (10^{-4} – 10^{-7}) of diluted culture broth were inoculated on agar plates, and the agar plates were cultured in an incubator at 30°C for 2 or 3 days. After the colonies developed, the colonies with the smooth surface, viscous, and wet were selected and then cultured in a liquid medium for another 3 days.

Measurement of flocculating activity and microbial growth. The flocculating activities were measured by calculating the flocculating rate using the modified method of Yokoi *et al.* (1995), in which Kaolin clay was chosen as the solid phase in the 5 g/l suspension. After the pH of the suspension was adjusted to 7.0, 2 ml CaCl_2 was added then 2 ml of the centrifuged upper phase of culture broth was added to the 4 g/l Kaolin suspension and stirred for 2 min. After being allowed to settle for 5 min, sampling was done at a depth of 3 cm under the surface of the suspension and the absorbance (OD) of the sample was measured by a spectrophotometer at 550 nm. A control experiment, without the addition of any agent, was measured in the same manner. The flocculating rate (FR) was calculated according to the following equation:

$$\text{FR} = [(\text{ODc} - \text{ODs}) / \text{ODc}] \times 100$$

Where ODs is the absorbance of the sample at 550 nm and ODc is the absorbance of the control at 550 nm. In the following experiments, the flocculating activities were measured in the Kaolin clay suspensions using the same procedure described above. In this study, the absorbance of the culture broth was measured with a spectrophotometer at 600 nm.

Identification of the bioflocculants-producing microorganisms. Molecular identification of the selected isolates was performed by the amplification of 16S rDNA with eubacterial universal primers 27F and 1492R (Lane, 1991). Sequencing was performed using ABI PRISM dye terminator cycle sequencing kit with AmpliTaq DNA polymerase and an Applied Biosystems 373 DNA sequencer (Perkin-Elmer, Foster City, Calif.). The sequences were analyzed using the CHECK CHIMERA and the SIMILARITY RANK programs of the Ribosomal Database Project (Altschul *et al.*, 1990) also analyzed using the BLAST program (National Centre for Biotechnology Information) to determine the closest available database sequences. Selected rDNA sequences were aligned using the Clustal W program (Shingler, 1996). Published se-

quences were obtained from GenBank. A phylogenetic tree was constructed using Clustal W by distance matrix analysis and the neighbour-joining method (Saitou and Nei, 1987). Phylogenetic trees were displayed using TREEVIEW (Page, 1996).

Morphology and physiology of isolates. Morphological and physiological tests were performed as described by Moaledj (1984). Cell morphology (size, shape, arrangement) was determined by phase-contrast microscopy (at magnification 1250 \times) after 1 to 2 days of incubation at 18°C. Gram reaction and motility tests were performed with freshly prepared liquid cultures.

Production of bioflocculants. The composition of the medium for bioflocculant production was as follows: glucose 20.0 g, KH₂PO₄ 2.0 g, K₂HPO₄ 5.0 g, (NH₄)₂SO₄ 0.2 g, NaCl 0.1 g, urea 0.5 g and yeast extract 0.5 g per liter of deionized water with initial of pH 6.5 (Zheng *et al.*, 2008). Strains QUST2, QUST6 and QUST9 which gave flocculation activity above 75% were selected for producing bioflocculants (Table I). The strains were pre-cultured in 50 ml medium in 250 ml flasks on a rotary shaker (120 rpm) at 25°C for inoculation preparation. After 16 h of cultivation, the culture broth was used as seed culture and 1% of it was inoculated into 450 ml of medium in 1000 ml flask. Batch fermentations were carried out under the same cultivation conditions as those of the pre-cultivation. Medium samples were drawn at appropriate time intervals and monitored for pH, cell growth (OD at 600 nm) and flocculating activity. Five milliliters of culture broth were centrifuged at 8000 \times g for 15 min, and the cell-free supernatant was used as test bioflocculant to study the flocculating activity.

Bioflocculants activity under different pH and flocculant concentrations conditions. The fermentation broth was centrifuged at 8000 \times g for 15 min. An appropriate amount of supernatant was mixed with ethanol 95% at a volume to volume ratio of 1:4 to precipitate the bioflocculant. The resulting precipitate was collected by centrifugation at 8000 \times g for 15 min and re-dissolved in distilled water. After the precipitation procedure was repeated three times, the crude biopolymer was obtained. Subsequently, flocculating activity of the isolated flocculants under different pH conditions was measured. The reaction mixture suspension was adjusted to desired pH values using HCl and NaOH. The pH values of the test suspensions ranged from 3.0 to 10.0. To determine the maximum occurred value of flocculating activity the procedure described above was applied at pH 7 to a crude bioflocculant concentrations range from 5 to 100 mg/l.

Bioflocculant collection and purification. Production of the bioflocculants was performed in several 500 ml flasks containing 100 ml culture medium with 200 rpm agitation at 30°C. The composition of

the culture medium was as follows: sucrose, 20 g/l; yeast extract, 2.5 g/l; KH₂PO₄, 2 g/l; K₂HPO₄, 5 g/l and NaCl, 0.1 g/l. The initial pH was 7. After incubation for 48 h, the culture was centrifuged at 10 000 rpm for 15 min. Bioflocculant was initially remained in liquid form, therefore, the supernatant was collected. Cold ethanol was added into the supernatant with stirring at the ratio of 2:1 (v/v). The precipitate was obtained by centrifugation at 10 000 \times g for 3 min and washed with distilled water. After three such ethanol precipitations, the bioflocculant was dialyzed against deionized water overnight and then lyophilized to obtain purified bioflocculant.

Physical and chemical analysis of the bioflocculant. Elemental analysis was achieved with an elemental analyzer (PE 2400 II, Perkin Elmer Company, USA). Infrared spectra of the dried bioflocculants samples was recorded in the frequency range of 4000–400 per cm by a fourier transform infrared-raman Spectrophotometer (EQUINOX 55, Bruker Company, Germany) with KBr disks. The protein concentrations of the extracted bioflocculants were determined according to Bradford method (Bradford, 1976).

Results

Isolation of the bioflocculants-producing microorganisms and phylogenetic analysis. Totally 56 mucoid colonies were isolated from the soils and wastewater samples. Morphological test presented that these isolates were all convex and round edge. Most of the colonies were creamy color. The assessment of flocculation activities was carried out after 3 days cultivation, which found out that three isolates, QUST2, QUST6 and QUST9 had the flocculating capabilities above 75% (Table I). The streak plate technique was applied to purify the isolates QUST2, QUST6 and QUST9. According to the morphological and physiological characteristics, the strains were rod-shaped and Gram-positive bacteria.

Table I
Flocculating activity of bioflocculant-producing microorganisms isolated from different Qatari ecosystems

Sampling site	Isolates	Flocculation activity (%)
Dafna (soil)	QUST1	33.5
	QUST2	79.8
	QUST3	14.3
Smasmah (soil)	QUST4	0.0
	QUST5	9.2
CAS (soil)	QUST6	85.2
	QUST7	23.5
AbuNakhla Wastewater	QUST8	48.2
	QUST9	76.0

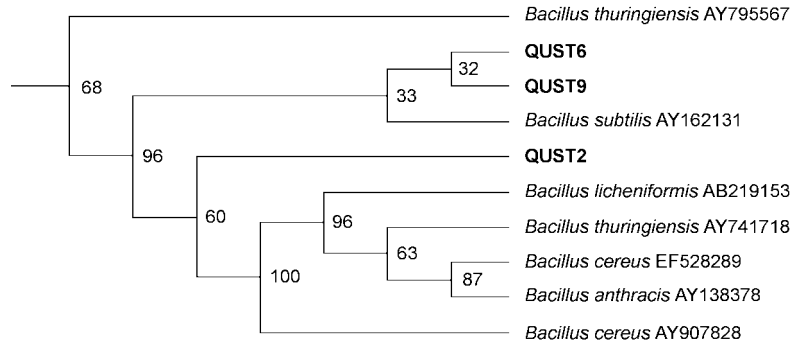

Fig. 1. Phylogenetic tree showing the relationships among selected strains (in boldface) and published 16S rDNA sequences (their GenBank accession numbers are putted in the tree); bootstrap values per 100 bootstrap analyses are also presented. The microorganism *Bacillus thuringiensis* AY795567 was used as an out-group.

The 16S rDNA were partially sequenced following PCR amplification and compared with sequences deposited in databases. Totally ~550 bp of the 16S rDNA of strains QUST2, QUST6 and QUST9 was

determined. The phylogenetic tree (Fig. 1) showed that strains QUST2, QUST6 and QUST9 formed evolutionary lineage within the radiation of a cluster comprising the *Bacillus* sp. the highest level of 16S rDNA

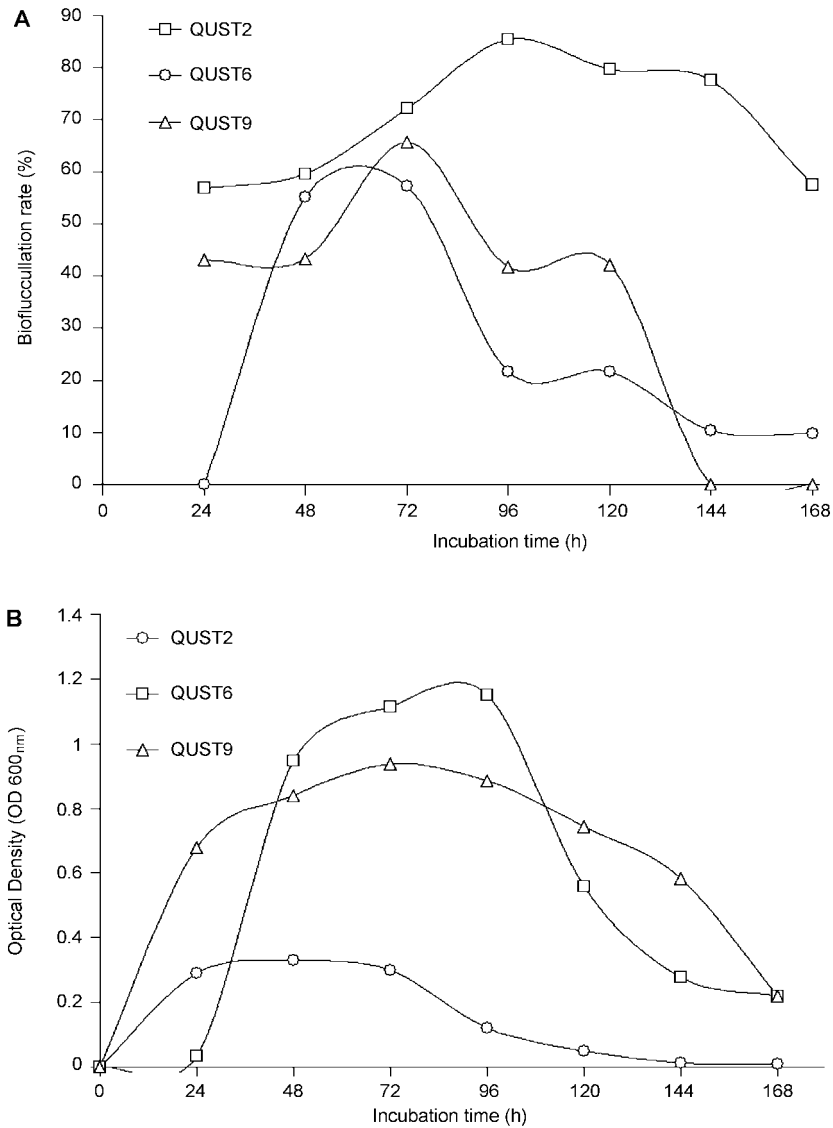

Fig. 2. Production of bioflocculants (A) and cell growth rates (B) of examined bacterial strains QUST2, QUST6 and QUST9, respectively.

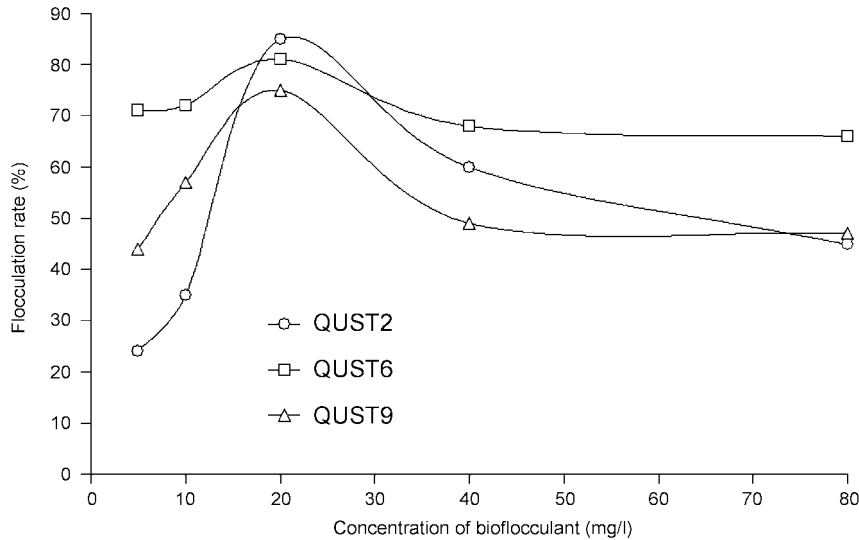

Fig. 3. Effects of bioflocculants concentrations on flocculation activity.

sequence similarity being to *Bacillus subtilis* and *Bacillus licheniformis* (>99%).

Production of bioflocculants. The growth curve of the strains and the flocculation activity of the culture broth are shown in Figure 2 A and B, respectively. During the fermentation process, the flocculating activity of the cell free supernatant of strain QUST2 started at 53% after 24 h incubation and then gradient increase was observed to reach the maximum (~85%) after incubation for 96 h, and then started to decrease slightly at 120 h. However, no flocculation activity was recorded with strain QUST9 in the first 24 h and then low flocculation rate was noticed at 48 h (43%) to reach the maximum (57%) after 72 h incubation. Strain QUST9 gave a maximum flocculation activity (65%) after 72 h of incubation, as well. As presented in Figure 2B, the cells of the isolates grew rapidly with increase of culture time in the first 72 h

of cultivation, and then leaved off. The flocculation activity curve was parallel to the cell growth curve and the flocculation activity increased with increasing culture time. However, the growth rate of isolate QUST6 was 4–5 times higher than the growth rate of isolate QUST6 and about two times higher than the growth rate of isolate QUST9.

Effect of the bioflocculant dosage. As shown in Fig. 3, the typical flocculation curve of the biopolymer showed the relationship between the concentration of the bioflocculant and its flocculating activity. The flocculating activities of kaolin suspension was around 85% when the flocculants concentrations were adjusted to the range of 10.0–40.0 mg/l and the corresponding maximum flocculating rates were achieved at bioflocculant dosage of 20.0 mg/l.

Effect of pH on flocculation. The experiments were carried out with the range of pH 3–10. The initial

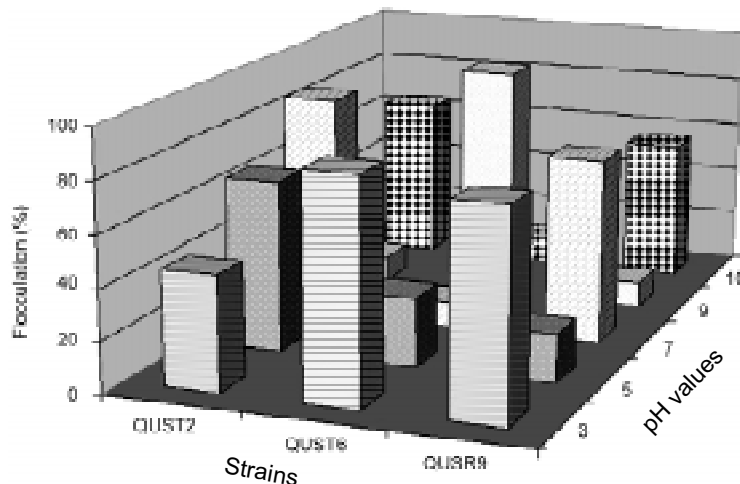

Fig. 4. Effects of pH on flocculation activity.

Table II

The elemental analysis of purified biofloculants produced by examined bacterial strains QUST2, QUST6 and QUST9, respectively

Strains	Carbon (%)	Hydrogen (%)	Nitrogen (%)	Sulfur (%)
QUST2	42.14	6.51	11.61	1.48
QUST6	47.27	8.18	12.10	1.52
QUST9	46.76	8.15	11.99	1.64

biofloculants concentrations were 20 mg/l. As can be seen from Figure 4, the flocculating capabilities were observed at pH values 3, 5, 7 and 10 with strain QUST2, 3 and 7 with strain QUST6 and 3, 7 and 10 with strain QUST9, respectively. The flocculating activities of all strains dropped with the rest of tested pH values. The maximum flocculating rates were observed at pH 7, 7 and 3 for the strains QUST2, QUST6 and QUST9, respectively.

Analysis of biofloculants composition. The elemental analysis of the biofloculant revealed the mass proportion of C, H, N and S (w/w) as presented in Table II. To investigate the characteristics of the biofloculants produced by three tested strains: QUST2, QUST6 and QUST9, the FT-IR spectrum of the pure biofloculant was analyzed for the functional groups in the biofloculants molecules. As shown in Fig. 6 the strong broad band with the peak at 3315 cm^{-1} can be assigned to the stretching vibration of OH and NH groups. As they have an overlapping band ranging from about 3100 to 3700 cm^{-1} , this FT-IR spectrum

cannot give a clear identification of the individual contribution of the OH, NH or both groups. However, the band at $1020\text{--}1049\text{ cm}^{-1}$ corresponding to the CO stretching vibration in alcohols suggests the presence of OH group in the flocculants. The peak at $1657\text{--}1640\text{ cm}^{-1}$ may be due to the C-O stretching in CO-NH group or NH₂ bending, and the peak at $1540\text{--}1562\text{ cm}^{-1}$ is attributed to the C N H bending in CONH group. In addition, the peaks at 2913 , 1383 and 809 cm^{-1} can be assigned to the CH stretching, CN stretching and NH₂ wagging vibration, respectively. Therefore, hydroxyl (OH), amide (CONH) and primary amine (NH₂) groups are present in the all characterized biofloculants molecules QUST2, QUST6 and QUST9. Total protein assay indicated that the protein content of the biofloculants produced by strains St2, St6 and St9 were 80, 78 and 89% respectively.

Discussion

Most biofloculants are produced by microorganisms during their growth periods (Kwon *et al.*, 1996; Nakata and Kurane, 1999; Shih *et al.*, 2001). Bacteria can utilize the nutrients in the culture medium to synthesize high molecular weight polymers internally within the cell under the action of specific enzymes, and these polymers can be excreted and exist in the medium or on the surface of the bacteria as capsule. Therefore, the action of bacteria converts the simple

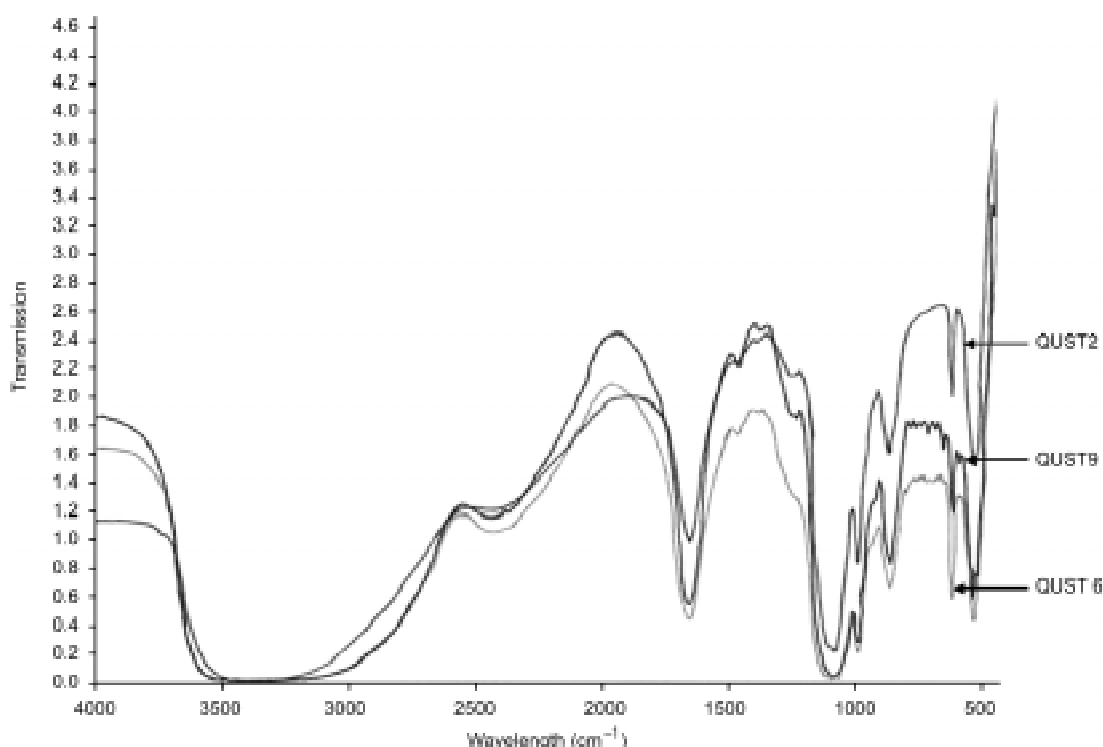

Fig. 5. FT-IR spectrum of the biofloculants produced by examined bacterial strains QUST2, QUST6 and QUST9, respectively.

Table III
Optimal dosage of different bioflocculants for solid suspensions with Ca⁺ ions as cation supplements

Microorganisms	Optimum concentration (mg/l)	Flocculating rate	References
<i>Bacillus</i> sp. DYU1	40	97	Wu and Ye, 2007
<i>B. licheniformis</i> CCRC12826	3.7	8.5	Shih <i>et al.</i> , 2001
<i>Bacillus</i> sp. PY-90	20	33	Yokoi <i>et al.</i> , 1995
<i>Bacillus coagulans</i> As-101	30	92	Salehizadeh <i>et al.</i> , 2000
<i>B. subtilis</i>	20	21.3	Yokoi <i>et al.</i> , 1996
<i>Klebsiella pneumoniae</i> H12	10	data not shown	Nakata and Kurane, 1999
<i>Gyrodinium impudicum</i> KG03	1	90	Yim <i>et al.</i> , 2007
<i>Bacillus</i> sp QUST2	20	85	Present study
<i>Bacillus</i> sp QUST6	20	81	Present study
<i>Bacillus</i> sp QUST9	20	75	Present study

substances in their environment into complex polymers that can be used as flocculant.

The flocculating activity of the polymers in this study was determined using Kaolin clay suspension as a flocculation test material. This criterion was previously employed by many researchers (Kwon *et al.*, 1996; Yokoi *et al.*, 1995). The results indicated that the flocculant from microorganisms had a very high flocculating activity. As a consequence, it could be widely used in many area of industry including wastewater treatment. From Figure 2, it can be seen that flocculating rate and growth of the examined strains increase with increasing cultivation time, indicating that the flocculant is produced by these bacteria during their growth. The three isolates; QUST2, QUST6 and QUST9 which gave the highest flocculating rate (>75%) were selected for identification. These strains were found to be Gram-positive with rod shape and motile. According to their 16S rDNA sequence analysis they are belonging to genus of *Bacillus*. In general it is known that the genus *Bacillus* includes a variety of industrially important species and has a history of safe use in both food and industry. The highest flocculating rates were achieved at bioflocculants dosage of 20.0 mg/l. However, the depression of flocculating activity at high concentration of all bioflocculants is largely due to incomplete dispersion of excess bioflocculant (Suh *et al.*, 1997). Table III summarizes some of bioflocculant-producing microorganisms and their optimum dosage for flocculation on kaolin suspension reported in the literature which indicated that the bioflocculant produced by *Bacillus* species representatives isolated in the present study was an effective flocculating agent with low dosage requirement. As presented in Figure 5, pH effective values were slight different from a previous study reporting that the flocculating activity of the bioflocculant produced by *S. griseus* was observed within the pH 2–6 and the maximum value

was obtained at pH 4 (Shimofuruya *et al.*, 1996). The maximum activity of the bioflocculant produced by *Gyrodinium impudicum* KG03 was observed at pH 4 with pH range of approximately 3–6 (Yim *et al.*, 2007).

It is known that *Bacillus* isolates made use of soluble starch and other nutrients and produced a polysaccharide or glycoprotein bioflocculant. Despite of that the starch can be modified into a flocculant through chemical reaction (Khalil and Aly, 2001), the grafting degree is low and the flocculating capability of the product is usually unsatisfactory. Through the action of bacteria, starch can be easily changed into an effective polysaccharide or glycoprotein bioflocculant. However, different bacteria may produce different bioflocculants. For example, *R. erythropolis* S-1 (Takeda *et al.*, 1991), *Bacillus licheniformis* (Shih *et al.*, 2001), *Pacilomyces* sp. (Hiroaki and Kiyoshi, 1985) and *Nocardia amarae* YK1 (Takeda *et al.*, 1992) produce protein bioflocculants. *Alcaligenes latus* KT201 (Toeda and Kurane, 1991), and *Bacillus subtilis* IFO3335 (Yokoi *et al.*, 1996) produce polysaccharide bioflocculant, while *Arcuadendron* sp. TS-4 (Lee *et al.*, 1995) and *Arathrobacter* sp. (Wang *et al.*, 1995) produce glycoprotein bioflocculant.

In our research, as confirmed by FT-IR analysis, elemental analysis and determination of protein content, the major component of the three extracted bioflocculants is closely related to glycoprotein. In comparison, pure protein bioflocculants are usually not heat-stable as protein can be destroyed upon heating (Takeda *et al.*, 1991). However, if the major component of a bioflocculant is a glycoprotein, its stability will depend on the relative contents of protein and polysaccharide. For protein bioflocculants, the amino and carboxyl groups are the effective groups for flocculation (Kurane *et al.*, 1994). In contrast, glycoprotein bioflocculants have many functional groups (Kurane *et al.*, 1991).

The presence of hydroxyl group by the FT-IR spectra within the polymer favored the possibility of hydrogen bonding with one or more water molecules, so all bioflocculants exhibited high solubility in aqueous solution, following the solubility principle "like dissolves like". A major condition for flocculation is that the molecules of flocculants could adsorb onto the surface of particles. The charge of kaolin particles in aqueous solution is negative. When bioflocculants were approaching particles in solution, an attractive force must exceed the electrostatic repulsion force. The calcium ion is necessary for the flocculating activity of bioflocculants on kaolin. This can be explained in that calcium ions stimulates flocculating activity by neutralizing and stabilizing the residual charge of functional groups as the binding distance is shortened (Kwon *et al.*, 1996). Then OH, COOH or COO⁻ groups of the bioflocculant and H, OH groups on the surface of particles might form hydrogen bonds as the bioflocculant chains approach the surface particles.

In conclusion, it is anticipated that bioflocculants product would be utilized not only in the area of wastewater treatment, but also in drinking water processing and food and fermentation industry because of its effective flocculation and harmlessness towards humans and the environment. The practical applications of the isolated bioflocculants in industry would be developed in further progress.

Acknowledgments

This study was made possible by a grant from the Qatar National Research Fund under number of 4-1-71. Its contents are solely the responsibility of the authors and do not necessarily represent the official views of the Qatar National Research Fund.

Literature

- Altschul S.F., W. Gish, W. Miller, E.W. Myers and D.J. Lipman. 1990. Basic local alignment search tool. *J. Mol. Biol.* 215: 403–410.
- Bradford M.M. 1976. A rapid and sensitive method for quantitation of microgram quantities of protein utilizing the principle of protein-dye-binding. *Anal. Biochem.* 72: 248–54.
- Chen M. and L.P. Zhao. 2003. Biodiversity of bacterial isolates on three different media from coking wastewater treatment system. *Acta Microbiol. Sin.* 43: 367–371.
- Chen, P., S. Fu and M. Li. 2003. Characteristics and treatment of brewery wastewater. *J. Water Poll. Cont.* 16: 146–149.
- Deng B., B. Bai and M. Hu. 2003. Characteristics of a bioflocculant produced by *Bacillus mucilaginosus* and its use in starch wastewater treatment. *Appl. Microbiol. Biotechnol.* 60: 588–593.
- Deng S., G. Yu and Y.P. Ting. 2005. Production of a bioflocculant by *Aspergillus parasiticus* and its application in dye removal. *Colloids Surf. B. Biointerfaces* 44: 179–186.
- He N., Y. Li and J. Chen. 2004. Production of a novel polygalacturonic acid bioflocculant REA-11 by *Corynebacterium glutamicum*. *Bioresour. Technol.* 94: 99–105.
- Hiroaki T. and K. Kiyoshi. 1985. Purification and chemical properties of a flocculant produced by *Paecilomyces*. *Agric. Biol. Chem.* 49: 3159–3164.
- Huang W., W. Cheng and Y. Hu. 2005. Screening of flocculant-producing strains by NTG mutagenesis. *J. Environ. Sci.* 17: 494–498.
- Khalil M.I. and A.A. Aly. 2001. Preparation and evaluation of some cationic starch derivatives as flocculants. *Starch/Staerke* 53:84–89
- Kurane R., K. Hatamochi, T. Kakuno, M. Kiyohara, K. Kawaguchi, Y. Mizuno, M. Hirano and Y. Taniguchi. 1994. Purification and characterization of liquid bioflocculant produced by *Rhodococcus erythropolis*. *Biosci. Biotechnol. Biochem.* 58: 1977–1982.
- Kurane R. and Y. Nohata. 1991. Microbial flocculation of waste liquids and oil emulsion by a bioflocculant from *Alcaligenes latus*. *Agric. Biol. Chem.* 55: 1127–1129.
- Kurane R., K. Toeda and K. Takeda. 1986. Culture condition for production of microbial flocculant by *Rhodococcus erythropolis*. *Agric. Biol. Chem.* 50: 2309–2313.
- Kwon G.S., S.H. Moon, S.D. Hong, H.M. Lee, H.S. Kim, H.M. Oh and B.D. Yoon. 1996. A novel flocculant biopolymer produced by *Pestalotiopsis* sp KCTC 8637P. *Biotechnol. Lett.* 18: 1459–1464.
- Lane D.J. 1991. 16S/23S rRNA sequencing. pp. 115–148. In E. Stackebrandt, and M. Goodfellow (ed.), *Nucleic Acid Techniques in Bacterial Systematics*. John Wiley & Sons, Inc., New York, N.Y
- Lee S.H., S.O. Lee, K.L. Jang and T.H. Lee. 1995. Microbial flocculant from *Arcuadendron* sp. TS-49. *Biotechnol. Lett.* 17: 95–100
- Li Y., N. He and H. Guan. 2003. A novel polygalacturonic acid bioflocculant REA-11 produced by *Corynebacterium glutamicum*: a proposed biosynthetic pathway and experimental confirmation. *Appl. Microbiol. Biotechnol.* 63: 200–206.
- Moaledj K. 1984. Über schnelle miniaturisierte Bestimmungsverfahren für Bakterienpopulationen in aquatischen Ökosystemen. *Arch. Hydrobiol.* 100: 99–121.
- Nakata K. and R. Kurane. 1999. Production of an extracellular polysaccharide bioflocculant by *Klebsiella pneumoniae*. *Biosci. Biotechnol. Biochem.* 63: 2064–2068.
- Page R.D. 1996. TREEVIEW: an application to display phylogenetic trees on personal computers. *Comput. Appl. Biosci.* 12: 357–358.
- Saitou N. and M. Nei. 1987. The neighbour-joining method: a new method for reconstructing phylogenetic trees. *Mol. Biol. Evol.* 4: 406–425.
- Salehizadeh H. and A. Shojaosadati. 2001. Extracellular biopolymeric flocculants: Recent trends and biotechnological importance. *Biotechnol. Adv.* 19: 371–385.
- Salehizadeh H., M. Vossoughi and I. Alemzadeh. 2000. Some investigations on bioflocculant producing bacteria. *Biochem. Eng. J.* 5: 39–44.
- Shih I.L., Y.T. Van, L.C. Yeh, H.G. Lin and Y.N. Chang. 2001. Production of a biopolymer flocculant from *Bacillus licheniformis* and its flocculation properties. *Bioresour. Technol.* 78: 267–272.
- Shimofuruya H., A. Koide, K. Shiota, T. Tsuji, M. Nakamura and J. Suzuki. 1996. The production of flocculating substance(s) by *Streptomyces griseus*. *Biosci. Biotechnol. Biochem.* 60: 498–500
- Shingler V. 1996. Molecular and regulatory checkpoints in phenol degradation by *Pseudomonas* sp. CF600. pp. 153–164. In Nakazawa T, Furukawa K, Haas D, Silver S (ed.), *Molecular Biology of Pseudomonads*. American Society for Microbiology, Washington, D.C.

- Suh H.H., S. Kwon, C. Lee, S. Oh, M. Kim, D. Yoon.** 1997. Characterization of bioflocculant produced by *Bacillus* sp. DP-152. *J. Ferment. Bioeng.* 84: 108–111.
- Takagi H. and K. Kadowaki.** 1985. Flocculant production by *Paecilomyces* sp. Taxonomic studies and culture conditions for production. *Agric. Biol. Chem.* 49: 3153–3157.
- Takeda M., J. Koizumi, H. Matsuoka and I. Hikuma.** 1992. Factors affecting the activity of a protein bioflocculant produced by *Nocardia amarae*. *J. Ferment. Bioeng.* 74: 408–409.
- Takeda M., R. Kurane, J. Koizumi and I. Nakamura.** 1991. A protein bioflocculant produced by *Rhodococcus erythropolis*. *Agric. Biol. Chem.* 55: 2663–2664.
- Toeda K. and R. Kurane.** 1991. Microbial flocculant from *Alcaligenes cupidus* KT201. *Agric. Biol. Chem.* 55: 2793–2799.
- Wang Z., K. Wang and Y. Xie.** 1995. Bioflocculant-producing microorganisms. *Acta Microbiol. Sin.* 35: 121–129.
- Wu J.Y. and H.F. Ye.** 2007. Characterization and flocculating properties of an extracellular biopolymer produced from a *Bacillus subtilis* DYU1 isolate. *Process Biochem.* 42: 1114–1123.
- Yim J.H., S.J. Kim, S.H. Ahn and H.K. Lee.** 2007. Characterization of a novel bioflocculant, p-KG03, from a marine dinoflagellate, *Gyrodinium impudicum* KG03. *Bioresour Technol.* 98: 361–367.
- Yokoi H, T. Arima, S. Hayashi and Y. Takasaki.** 1996. Flocculation properties of poly(γ -glutamic acid) produced by *Bacillus subtilis*. *J. Ferment. Bioeng.* 82: 84–87.
- Yokoi H., O. Natsuda, J. Hirose, S. Hayashi and Y. Takasaki.** 1995. Characteristics of abiopolymer flocculant produced by *Bacillus* sp. PY-90. *J. Ferment. Bioeng.* 79: 378–380.
- Yokoi H., T. Arima, J. Hirose, S. Hayashi and Y. Takasaki.** 1996. Flocculation properties of poly(γ -glutamic acid) produced by *Bacillus subtilis*. *J. Ferment. Bioeng.* 82: 84–87.
- Zhang J., Z. Liu and S. Wang.** 2002. Characterization of a bioflocculant produced by the marine myxobacterium *Nannocystis* sp. NU-2. *Appl. Microbiol. Biotechnol.* 59: 517–522.
- Zheng Y., Z. Ye, X. Fang, Y. Li and W. Cai.** 2008. Production and characteristics of a bioflocculant produced by *Bacillus* sp. F19. *Bioresour. Technol.* doi:10.1016/j.biortech.2008.01.068.